

# WM5000 Series Mount

## WALL MOUNT KITS FOR ENDURA™ SYSTEM MODULES



### Product Features

- Any Orientation for Wall-Mounted Modules
- Wall Brackets Accommodate Single-Width Module Sleeves
- Rubber Feet Attached to Wall Brackets for Desktop Placement
- Aesthetic Cover Plates
- Optional Expansion Kit for Applications Where Wall Space Is a Premium
- Integrates with Pelco Fiber Modules Via RK5001-1UEXP, RK5002-1UEXP, and RK5003-1UEXP
- Integrates with Stand-Alone Power Supplies

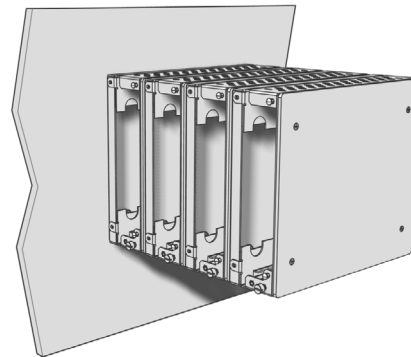

**MAXIMUM OF FOUR MODULE SLEEVES ATTACHED TO A WALL.  
SHOWN ABOVE: (1) WM5001-4U AND (3) WM5001-4UEXP**

You can install up to four Endura™ system modules when using the **WM5001-4U** wall mount kit. This base kit includes a wall bracket that can be mounted onto a wall in any orientation and a module sleeve with cover plate. The **WM5001-4UEXP** expansion kit includes an additional module sleeve. You can purchase three expansion kits and attach the module sleeves to the base kit for a maximum of four module sleeves.

The module sleeve interlocks with the wall bracket and is secured with thumbscrews. The wall brackets have rubber feet giving you the option of placing them on a desk and stacking the modules.

The **WM5001-4U** facilitates installation into areas that may not have a standard rack available. Its unique design allows for installation in a very small wall space since all of the connections are inside the framework of the module dimensions.

*Endura distributed, network-based products are available only to certified dealers/integrators. Please contact your local sales representative for details on certification applications and requirements. Additional information on Endura products and certifications may be found at <http://www.pelco.com/endura>*



# TECHNICAL SPECIFICATIONS

## MODELS

WM5001-4U Wall-mount base kit for one module

## MECHANICAL

Number of Modules One  
Module Orientation Variable  
Construction Aluminum  
Finish Black

## GENERAL

Dimensions\* 6.69" D x 7.88" W x 2.19" H  
(16.99 x 20.02 x 5.56 cm)  
Mounting Wall or desktop  
Unit Weight  
WM5001-4U 1.46 lb (0.66 kg)  
WM5001-4UEXP 0.42 lb (0.19 kg)  
Shipping Weight  
WM5001-4U 2.70 lb (1.22 kg)  
WM5001-4UEXP 1.65 lb (0.75 kg)

\*The dimensions are based on the orientation of the wall mount as shown in the photo.

## OPTIONAL ACCESSORIES

WM5001-4UEXP Wall-mount expansion kit for an additional module; use three with WM5001-4U base kit for a maximum of four modules per wall location  
NET5301PS Power Supply Single module; 12 VDC  
MCS Series Power Supply 24 VAC output voltage  
TF2000 Power Supply 24 VAC output voltage

## CERTIFICATIONS

- UL Listed
- UL Listed to Canadian safety standards
- Complies with Argentina compliance requirements under Res. 92/98.



### Pelco Worldwide Headquarters:

3500 Pelco Way, Clovis, California 93612-5699 USA  
**USA & Canada** Tel: (800) 289-9100 • FAX (800) 289-9150  
**International** Tel: (559) 292-1981 • FAX (559) 348-1120  
[www.pelco.com](http://www.pelco.com)

Pelco and the Pelco logo are registered trademarks of Pelco.  
Endura is a trademark of Pelco.  
Specifications subject to change without notice.  
©Copyright 2006, Pelco. All rights reserved.